

No. 711,920.

Patented Oct. 21, 1902.

J. BRIDGES.
HAND CAR.

(Application filed Feb. 15, 1902.)

2 Sheets—Sheet 1.

(No Model.)

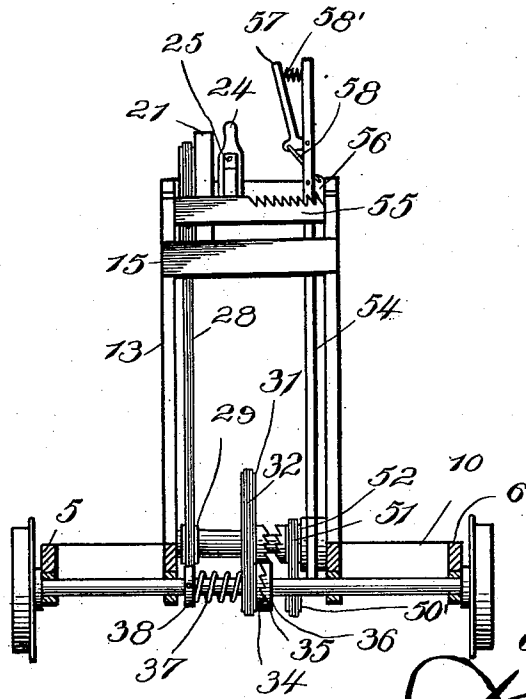
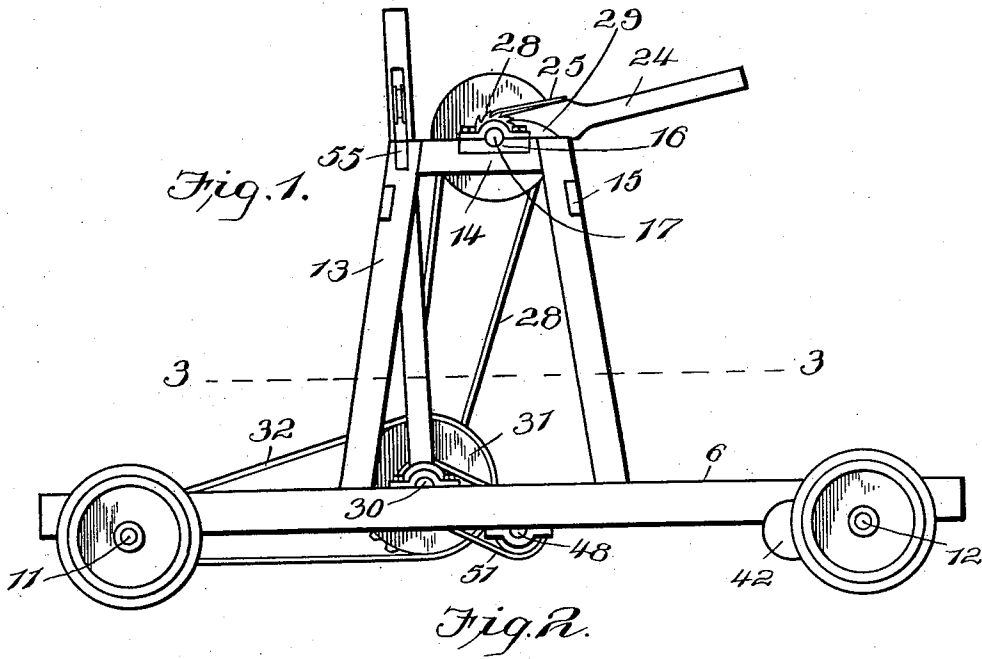

Witnesses

J. P. Britt

Harry Eslin R. Barden

Inventor

J. Bridges,

Attorneys

J. BRIDGES.
HAND CAR.

(Application filed Feb. 15, 1902.)

(No Model.)

2 Sheets—Sheet 2.

Fig. 3.

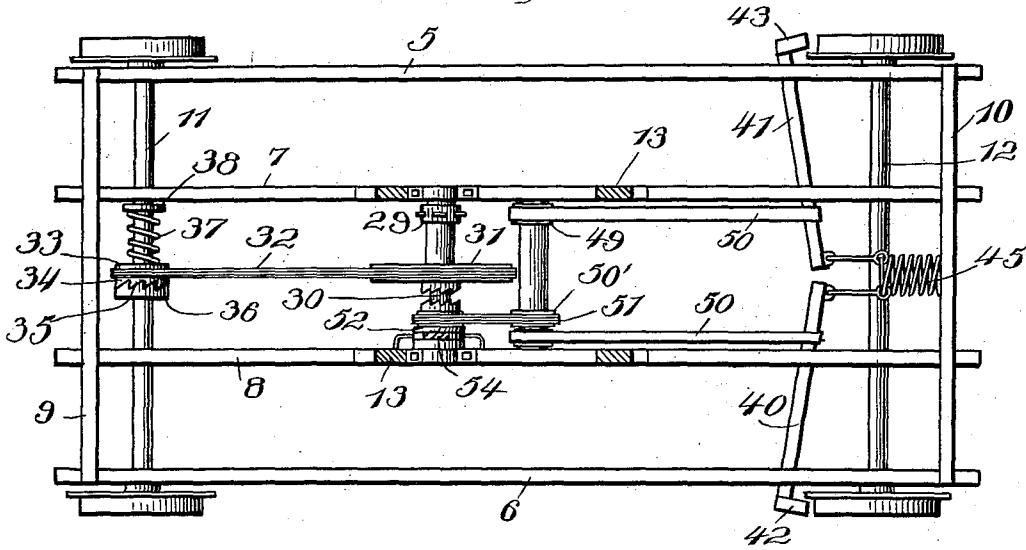
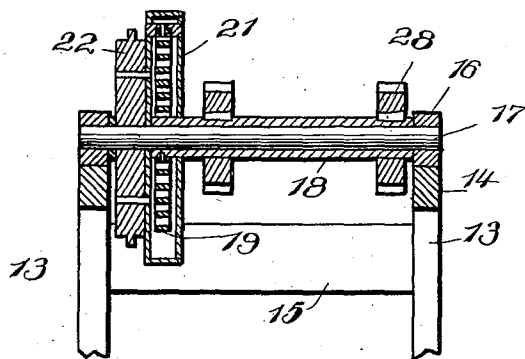

Fig. 4.



Witnesses

T. P. Brett
Harry Z. Linchauer

Inventor

J. Bridges
[Signature]
 Attorneys

UNITED STATES PATENT OFFICE.

JOHN BRIDGES, OF IMBODEN, ARKANSAS, ASSIGNOR OF ONE-HALF TO
JAMES WILLIS HUFSTEDLER, OF IMBODEN, ARKANSAS.

HAND-CAR.

SPECIFICATION forming part of Letters Patent No. 711,920, dated October 21, 1902.

Application filed February 15, 1902. Serial No. 94,187. (No model)

To all whom it may concern:

Be it known that I, JOHN BRIDGES, a citizen of the United States, residing at Imboden, in the county of Lawrence, State of Arkansas, have invented certain new and useful Improvements in Hand-Cars; and I do hereby declare the following to be a full, clear, and exact description of the invention, such as will enable others skilled in the art to which it ap-
10 pertains to make and use the same.

This invention relates to hand-cars; and it has for its object to provide a simple and efficient construction which includes an energizing-spring having a lever for winding it and connected with a winding-shaft and a drum, so that when the spring is wound up by operation of the lever the drum will be rotated to drive the apparatus. When desired, the energy of the spring may be shifted
20 from the driving-wheels to the brake mechanism for setting the latter.

In the drawings, in which like numerals of reference indicate similar parts in the several views, Figure 1 is a side elevation showing the hand-car and its propelling mechanism. Fig. 2 is a vertical section taken in the plane of the driven axle of the car and showing the driving mechanism in elevation. Fig. 3 is a section on the line 3 3 of Fig. 1 and showing
25 the brake mechanism. Fig. 4 is a vertical section through the upper portion of the mechanism and including a spring-drum, the shaft of the drum being in elevation.

Referring now to the drawings, the hand-car includes a platform comprising outside sills 5 and 6, inside sills 7 and 8, and front and rear cross-pieces 9 and 10, the sills having bearings in which is received the drive-axle 11, carrying the traction-wheel, and the
40 axle 12, which carries the brake-wheels. To rotate the drive-axle, a framework is provided upon the car and consists of uprights 13, having blocks 14 at their upper end disposed longitudinally of the car and having cross-braces 15. The blocks 14 have bearings 16, in which is received a winding-shaft 17, on which is loosely mounted a drum 18, having a ratchet-wheel at one end and to which drum is attached the inner end of a
50 spiral spring 19, the outer end of which is attached to the casing 21, which is mounted

loosely upon the shaft and has a sprocket-pulley 22 at one end and exteriorly of the casing. Thus if the spring be wound up the casing will be rotated to rotate the pulley. To rotate the winding-shaft and therewith
55 the drum to wind up the spring contained therein, a bifurcated lever 24 is disposed with its ends pivotally mounted upon the winding-shaft and at opposite sides of the ratchet-wheel thereon, this lever having a spring-pawl 25 engaged with the ratchet, so that as the lever is rocked upon the winding-shaft of the pivot the ratchet will be urged in one direction to wind up the spring. To prevent return rotation of the winding-shaft, a
60 ratchet 28 is fixed thereon and with which cooperates a pawl 29, pivoted to the supporting-blocks 14.

From the sprocket-pulley on the winding-shaft there leads a sprocket-chain 28 to a sprocket-pulley 29 on a counter-shaft 30, which is journaled in bearings on the sills 7 and 8. The counter-shaft carries a large sprocket-pulley wheel 31, with which is engaged a chain 32, leading to a sprocket-pulley
75 33 on the drive-axle. This sprocket-pulley 33 has a clutch-face 34 at one end, which cooperates with a similar face 35 of a clutch-drum 36, which is fixed on the drive-axle. The sprocket-pulley is mounted slidably and rotatably on the drive-axle and is held with its clutch-face in engagement with the face of the drum by means of a helical spring 37, disposed upon the shaft and between the ends
85 of the sprocket-pulley and a stop 38 on the shaft. As the spiral spring unwinds it operates the counter-shafts and therewith the sprocket-pulley 34 in a direction to engage the clutch-faces and to drive the drive-axle. If the sprocket-pulley on the drive-axle be held stationary, however, or against rotation, the spring that is disposed against it will yield and the clutch-faces will have a ratchet action with respect to each other, so that the
90 drive-axle will rotate freely. This action takes place when coasting.

The brake-wheels above referred to are provided with a brake mechanism consisting of levers 40 and 41, which are pivoted to the sills 5 and 6 and which are provided at their outer ends with the shoes 42 and 43 for engagement

with the wheels, and the levers are held normally with the shoes in operative positions by means of the helical spring 45, which is connected with the inner ends of the levers and with the cross-piece 10, as shown. To move the levers 40 and 41 to apply the brakes, a shaft 48 is mounted in the sills 7 and 8 and is provided with winding-drums 49, with which are engaged the straps 50, attached to the ends of the levers 40 and 41, so that when the winding-drums are rotated the straps will be wound up to move the lever and apply the brake. To rotate this shaft, it is provided with a sprocket-pulley 50, with which is engaged a sprocket-chain 51, leading to a sprocket wheel or pulley 52 on the counter-shaft, and which sprocket-pulley is slidably mounted for movement into and out of frictional engagement with the face of the sprocket-pulley 31, and when in frictional engagement it is rotated by this sprocket-pulley to rotate the winding-drums. To move the sprocket-pulley into and out of engagement with the sprocket-pulley 31, it is provided with a peripheral groove, in which are engaged the legs of a bifurcated lever 54, which is pivoted to the inner face of the sill 8 and extends upwardly and above the winding-shaft. The upper portion of the lever 54 has a slot in it, through which is passed a rack 55, engaged with the block 14, and with which rack cooperates a pawl 56, pivoted to the lever. A trigger 57 is likewise pivoted to the lever and has a link 58 connecting it with a pawl to raise the latter from the rack, the trigger being held in position to engage the pawl with the rack by means of a helical spring 58', disposed between the trigger and the lever. This pawl holds the lever with the shiftable sprocket-pulley on the counter-shaft in frictional engagement with the sprocket-pulley 31.

With this construction it will be seen that with the lever 54 thrown to one side, so as to release the brake mechanism, the lever 24 may be rotated to wind the spring, which in turn will operate the drive-shaft in the manner above described, and if the lever 54 be then shifted to an opposite position the brakes will be applied to stop the car.

In practice modifications of the specific construction shown may be made and any suitable materials and proportions may be used for the several parts without departing from the spirit of the invention.

With this construction it will be seen that the mechanism may be condensed, so that it will occupy a small space, thus giving more room for the passengers and tools to be con-

veyed. Furthermore, with the present construction danger to the passengers is reduced to a minimum.

What is claimed is—

1. A device of the class described comprising a drive-axle having drive-wheels, a second axle having brake-wheels, a spring-operated pulley, a counter-shaft operatively connected with the pulley, a clutch-drum on the drive-axle, a pulley on the drive-axle operatively connected with the clutch for moving the drum in one direction, a pulley upon the counter-shaft connected with the pulley on the drive-axle, a brake mechanism and means for throwing said brake mechanism into and out of operative relation with the pulley on the counter-shaft.

2. A hand-car comprising a platform having a drive-axle provided with wheels and a brake-axle provided with wheels, levers having shoes for engagement with the brake-wheel, winding-drums, connections between the brake-levers and the winding-drums for operating the levers, a counter-shaft, a clutch mechanism operatively connected with the counter-shaft for rotating the drive-axle in one direction, and a clutch operatively connected with the winding-drums and having means for operatively connecting it with the counter-shaft.

3. A hand-car comprising a platform including sills and cross-pieces, a winding-shaft having means for rotating it, a spiral spring connected at one end of the shaft, a drive-pulley connected with the opposite end of the spring for rotation thereby, a counter-shaft operatively connected with the drive-pulley, a drive-axle having a clutch member, a pulley mounted loosely upon a drive-axle and having a clutch-face, means for holding the pulley with the clutch-face yieldably in engagement with the clutch member, levers having brake-shoes, brake-wheels for engagement by the shoes, means for holding the shoes yieldably out of engagement with the wheels, a shaft provided with winding-drums, straps attached to the levers and to the drums to be wound upon the latter, and means for clutching the drum-shaft in operative relation to the counter-shaft.

In testimony whereof I hereunto sign my name in the presence of two subscribing witnesses.

JOHN BRIDGES.

Witnesses:

JNO. H. DAVIDSON,
C. E. LEWIS.