

(No Model.)

2 Sheets—Sheet 1.

C. ROBERTS.
HAND CAR.

No. 462,509.

Patented Nov. 3, 1891.

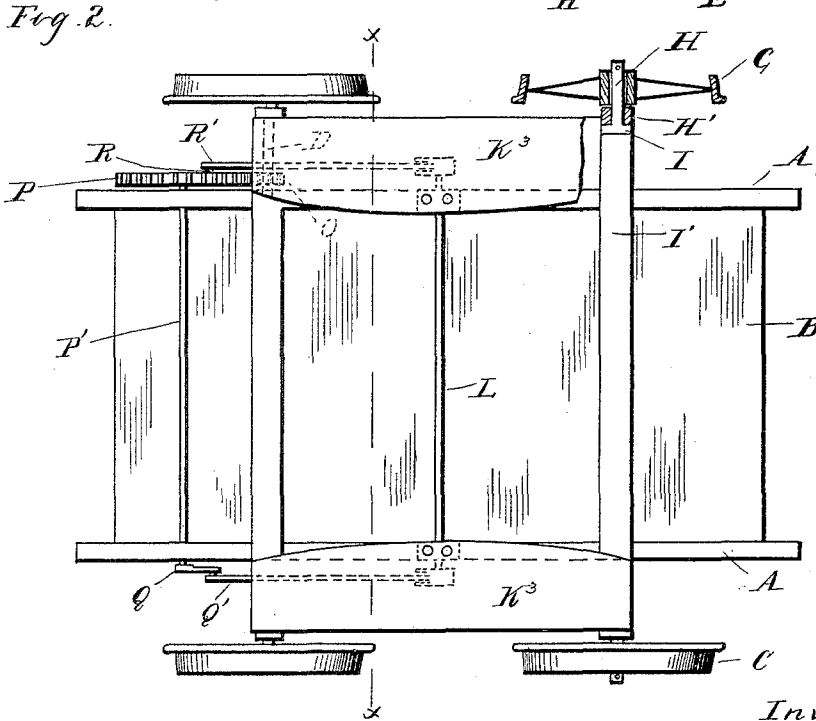
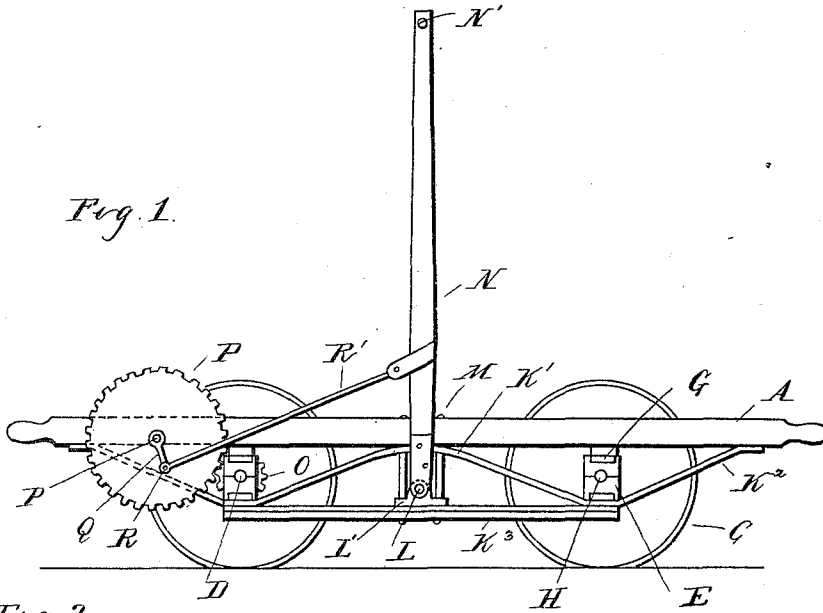

Witnesses
A. L. Hobbs
M. B. O'Boyle

Inventor
 Cyrus Roberts
 By *Mrs. Sprague* *Joy*
 Atty.

C. ROBERTS.
HAND CAR.

No. 462,509.

Patented Nov. 3, 1891.

Fig. 3.

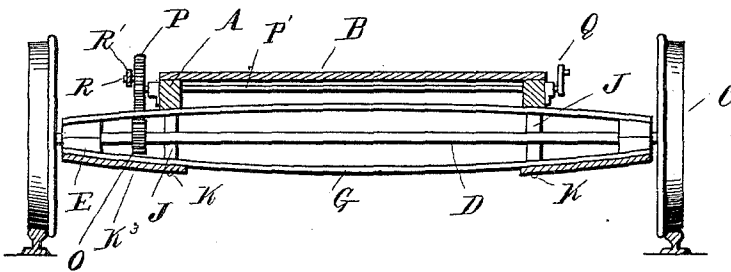

Fig. 4.

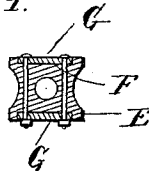
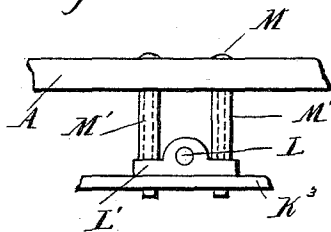

Fig. 5.



Witnesses
 A. L. Stubbie
 Th. B. O'Boyle

Inventor
 Cyrus Roberts
 By Thos. Spraguet
 Atty.

UNITED STATES PATENT OFFICE.

CYRUS ROBERTS, OF THREE RIVERS, MICHIGAN.

HAND-CAR.

SPECIFICATION forming part of Letters Patent No. 462,509, dated November 3, 1891.

Application filed May 27, 1891. Serial No. 394,308. (No model.)

To all whom it may concern:

Be it known that I, CYRUS ROBERTS, a citizen of the United States, residing at Three Rivers, in the county of St. Joseph and State of Michigan, have invented certain new and useful Improvements in Hand-Cars, of which the following is a specification, reference being had therein to the accompanying drawings.

This invention relates to new and useful improvements in hand-cars of that class especially designed for light work and high speed, generally known as "inspection-cars."

The invention consists in the peculiar construction of the frame, the axles, and the drive mechanism, and, further, in the peculiar construction, arrangement, and combination of the various parts, all as more fully hereinafter described and shown.

In the drawings, Figure 1 is a side elevation of my improved car with the wheels removed. Fig. 2 is a bottom plan view thereof, partly in section. Fig. 3 is a vertical cross-section on line *xx* in Fig. 2. Figs. 4 and 5 are detail views specifically referred to.

The frame of my car consists of two longitudinal beams A, covered with a suitable platform B. This frame is supported by means of suitable wheels C. There are two pairs of wheels, one pair forming the drive-wheels and the others being simply loosely secured upon their axles, the drive-wheels upon the shaft D running in boxes E. These boxes are provided on the top and bottom, respectively, with a gain or notch F, in which the end of the trussed frame G engages, as shown in Fig. 4, this frame consisting of two oppositely-curved bars, being secured in position at the ends by means of the bolts which secure together the two halves of the axle-box. The body of the car is supported upon the top of this trussed frame in any suitable manner. The other pair of wheels are supported upon stub-axles H, which pass through the boxes H', and are prevented from being disengaged therefrom by means of a head I, bearing against the inner sides of the boxes. These boxes are connected together by means of a similar trussed frame I', which at suitable intervals is held rigidly in position by means of struts J and clamping-bolts K. These bolts pass through the strut, truss, and platform

and clamp the whole together, as plainly shown in Fig. 3. The platform is of considerably less width than the distance between the wheels to give the requisite lightness. 55

The timbers A are trussed by means of trusses, which consist of a central arched portion K' between the axles or axle-frames, and the two end braces K² extend from these axle-frames to the bars A. The two axle-frames are connected together by means of auxiliary platforms K³, which form a part of the truss for the frame, acting the part of a chord connecting the two axle-frames. 60

L is a shaft journaled centrally of the car upon boxes L', secured to the auxiliary platform by suitable bolts M and sleeves M', which pass through the platform and serve to support the auxiliary platform at that point. 65

N are vertical levers engaging into any suitable sockets formed in the end of the shaft. 70

These levers N are connected together by means of the cross-bar N'. The drive-axle D is provided with a drive-pinion O at one end, with which a gear-wheel P engages, this gear-wheel being of suitable size to give the proper speed to the shaft. The gear-wheel P is journaled upon the shaft P', extending across the platform beneath the same, provided at one end with a crank Q, with which the connect- 75

ing-rod Q' engages, and at the other end upon the opposite side of the frame bearing a gear- 80

wheel P, upon which a crank-pin R is secured, with which the connecting-rod R' engages, all so arranged that the oscillating movement of 85

the levers N impart through the connecting-rods Q' R' a rotary motion to the gear-wheel P, which in turn actuates the drive-shaft D, which carries the drive-wheels of the car. I obtain by this construction a very light car 90

which will carry a large load, and also get a direct connection for my power to the drive- 95

shaft, whereby with the least exertion I may get a high speed, the auxiliary platform serving with a comparatively small amount of 95

added cost and weight to permit of carrying a large load of light stuff—such as lanterns—without detracting from the room on the plat- 100

form proper, and they also serve as a part of the truss for the frame by connecting the axle- 100

frames.

By making the axle-frames in the manner

described in connection with the stub-axles at one end I lighten the car without lessening its capacity to carry loads.

What I claim as my invention is—

5 1. In a hand-car, the combination, with the axles extending across the same, of trussed frames located above and below the axles, axle-boxes to which the frames are secured, and a platform on the frame, substantially
10 as described.

2. In a hand-car, the combination, with the axles, of trussed axle-frames secured at their ends to the axle-boxes and platforms above and below the frames, substantially as de-
15 scribed.

3. In a hand-car, the wheels, the axles jour- naled in axle-boxes, axle-frames formed of op- positely-curved bars engaging with the top and bottom of the axle-boxes, and a platform
20 supported thereon, substantially as described.

4. In a hand-car, the combination, with the longitudinal platform-timbers, the axle-frame formed of oppositely-curved bars engaging at the ends with the axle-boxes, and of truss-
25 bars for the platform-timbers secured to the axle-frames, substantially as described.

5. In a hand-car, the combination, with the platform, the axle-frames extending beyond the platform, and the auxiliary platforms sup-

ported on said extensions below the main plat- 30 form, substantially as described.

6. In a hand-car, the combination, with the axles, of frames supported thereon, a platform above the axles, and a platform suspended from and located below said other platform 35 and having its ends connected with the frames, substantially as described.

7. In a hand-car, the combination, with a platform and the axles, of a shaft extending below and across the platform, a hand-lever 40 secured to the end of the shaft at one side of the platform, a shaft extending across the end of the platform, a gear-wheel mounted on said shaft, a crank on the shaft, a connecting-rod between the lever and the crank, and a 45 pinion on one axle engaging with said gear, substantially as described.

8. In a hand-car, the combination, with the axles and platform, of auxiliary platforms at the sides of the car, and actuating-levers on 50 the sides of the car above the auxiliary plat- forms, substantially as described.

In testimony whereof I affix my signature in presence of two witnesses.

CYRUS ROBERTS.

Witnesses:

JAMES WHITTEMORE,
M. B. O'DOHERTY.