

116527 M.E. Hasting's
Improvement in Hand Cars.

Fig. 1.

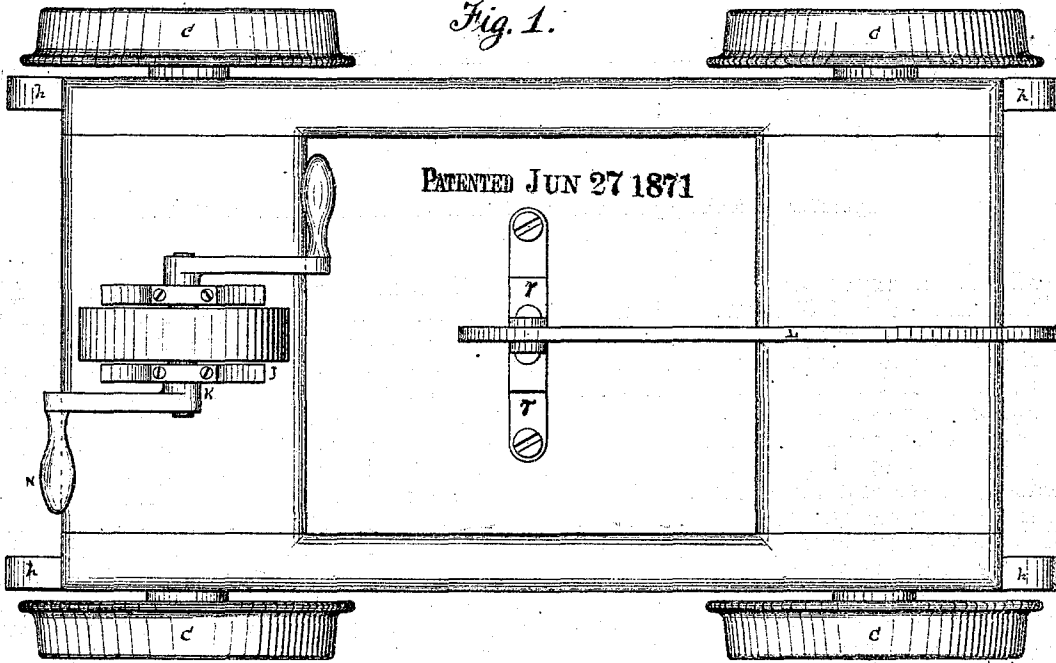
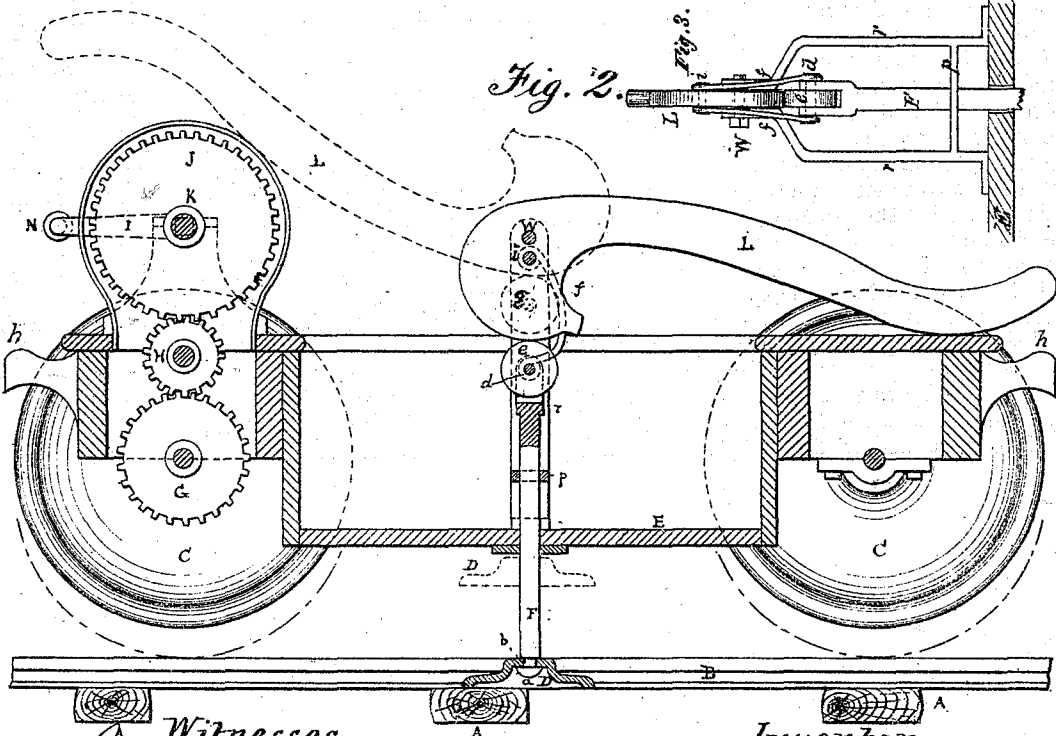

Fig. 2.



Witnesses.
Jas. H. Tomlinson
Wm. M. Grant

Inventor.
Martin E. Hasting by
A. M. Stout Attorney

UNITED STATES PATENT OFFICE.

MARTIN E. HASTINGS, OF SALISBURY, MARYLAND.

IMPROVEMENT IN HAND-CARS.

Specification forming part of Letters Patent No. 116,527, dated June 27, 1871.

To all whom it may concern:

Be it known that I, MARTIN E. HASTINGS, of Salisbury, in the county of Wicomico and State of Maryland, have invented certain Improvements in Hand-Cars for Railroads, of which the following is a specification:

My invention relates to a combination of devices by means of which a hand-car may be conveniently raised and turned across the track in order to be removed therefrom, which devices will be hereinafter more fully explained.

Figure 1 represents a plan view of a hand-car with my devices embraced in it. Fig. 2 represents a longitudinal vertical sectional view of the same. Fig. 3 represents an end view of the leg, floor of the car, cam-lever, and coasting devices for raising the car.

A A A indicate the cross-ties; B, one of the rails. C C C C are the carriage-wheels; E, the bottom of the hand-car; G, H, I, J, K, and N, the propelling mechanism of the car; all of which are of any ordinary construction. A frame, consisting of two upright pieces, *r r*, and cross-piece P, is secured to the bottom of the car. Through the cross-piece P, and down through a plate in the bottom of the car, passes the prop or leg F, which is pivoted at *b*, at its lower end, and secured by the nut *a* to the plate or disk D. When the leg is pressed down, as hereinafter described, the disk is brought in contact with a tie or the road-bed, and forms a bearing which supports the leg F and the car which it carries, and allows them to be turned on the pivot *b*. To the upper

end of the leg F is pivoted, at *d*, the friction-wheel *e*. At the top of, and between the uprights *r r*, is pivoted, at W, the cam-lever L. When this lever is thrown over into the position shown in the drawing it acts upon the friction-wheel *e*, presses down the leg F, and raises the car clear of the track, as shown. The leg F is suspended to the lever L by means of the links *f f*, secured at their lower ends to the pivot *d* and at their upper ends to the pin *i*. This pin is inserted in the lever L, eccentrically to its fulcrum, in such a position that when the lever is thrown over into the position indicated in dotted lines the pin takes a position above said fulcrum, carrying with it the links *f f* and the leg F, thus elevating the disk D clear of the ground and lowering the car so that it may rest upon its wheels. When the car is elevated as above described it may be turned round on the pivot *b*, then lowered, as described, and run off the track. To replace it upon the track the operation is reversed.

I have shown my invention applied to a hand-car, but it is evident it can be used on any car.

What I claim as my invention is—

The cam-lever L, the leg F with its pulley *e*, the hooks *f f*, and frame *r r* P, in combination, when constructed, arranged, and operated substantially as and for the purpose described.

MARTIN E. HASTINGS.

Witnesses:

JAS. H. LOWNDES,
ALEX. M. STOUT, Jr.